



3-IN-1 DRILL PRESS UPGRADE

storage
solutions

3-in-1 Drill Press Upgrade

Get storage, mobility, and accuracy from these three useful add-ons.

Making a drill press more useful is one of the bigger shop challenges. And when you have to move the drill press, it can be like wrestling a monster. Another problem is the small table on most drill presses isn't really designed for woodworking.

A solution for each of these problems is shown at right. First, a cabinet with full-extension drawers keeps all those accessories at hand. A mobile base makes moving the drill press a breeze. And best of all, the large table makes the drill press ideal for woodworking tasks.



Exploded View Details

OVERALL DIMENSIONS: 18"W x 5⁵/₈"H x 20¹/₂"D (BASE)
 22³/₄"W x 28"H x 21³/₄"D (CABINET)
 30"W x 4"H x 12"D (TABLE & FENCE)

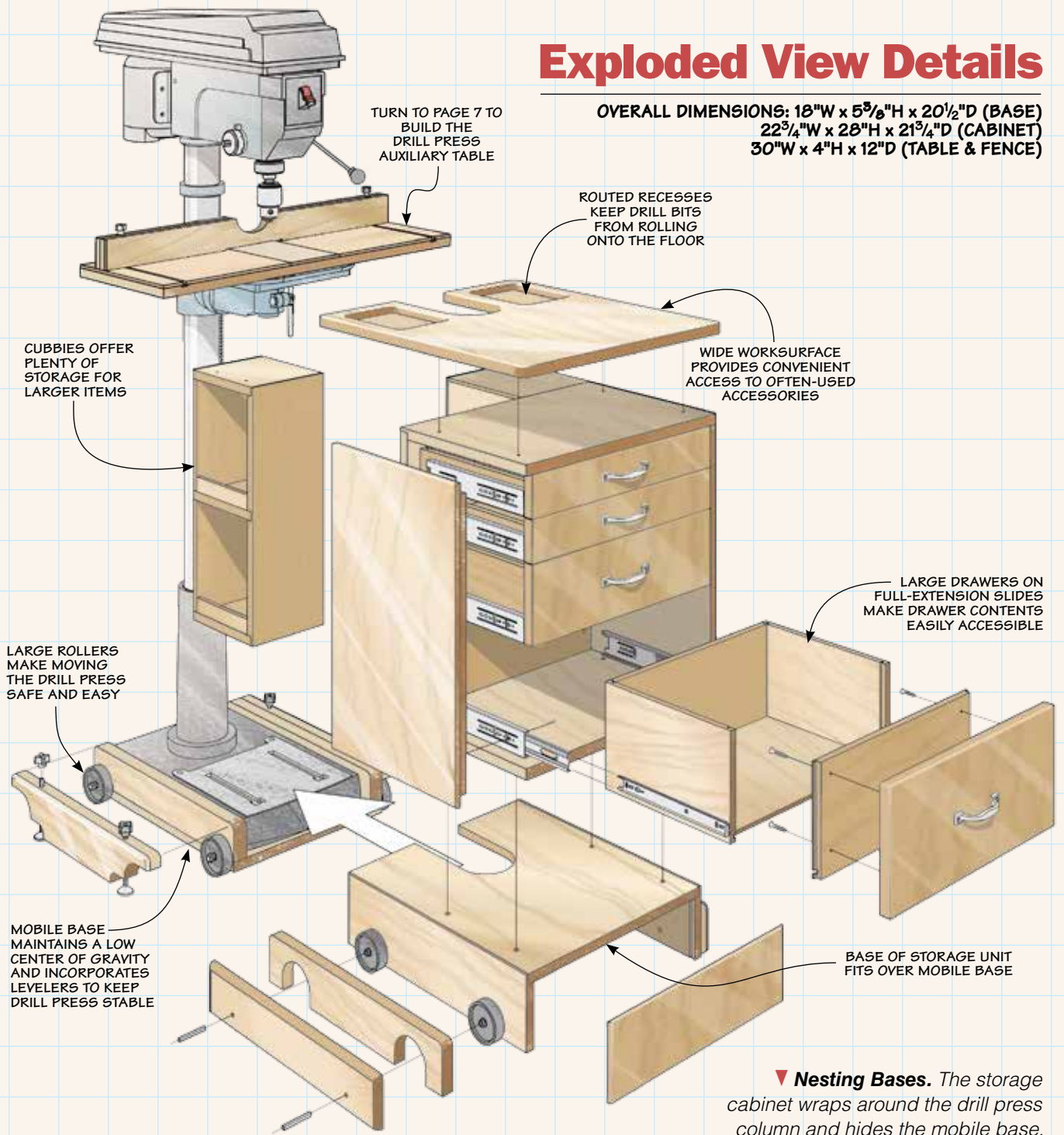

▼ **Nesting Bases.** The storage cabinet wraps around the drill press column and hides the mobile base.

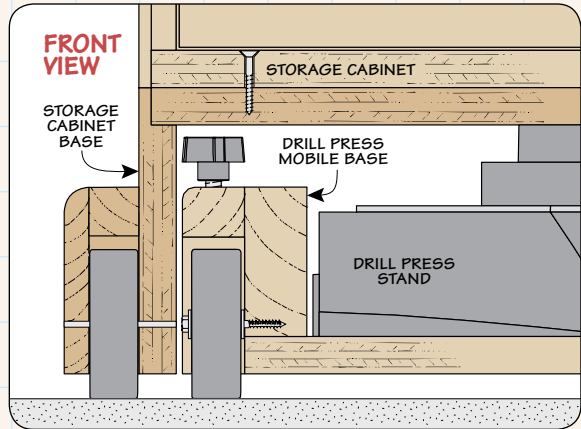

mobile Base

Adding a mobile base to a drill press can make it easier to relocate the tool or simply clean underneath. This mobile base has several worthwhile features besides being easy to build.

First, the low center of gravity keeps the drill press stable and less likely to tip. The large rollers make it easy to move around the shop, though you'll still want to keep the top-heavy drill press under control as you move it. Finally, the levelers lock the drill press in place for stability.

Simple Construction. The mobile base starts with a plywood panel. Two thick cleats attached to the upper face help bear the weight of the drill press. The wheels are fastened to the cleats. Wheel blocking adds stiffness and strength plus provides convenient mounting points for the levelers and their knobs.



▲ **Stability.** Moving a top-heavy drill press can be a chore. This mobile base not only makes the task easier, but once it's in place, the levelers lock it in position and add stability.

Base. You'll start by sizing the width of the plywood base panel to fit your drill press, adding an extra 2½" to account for the cleats (Figure 1). Drill the series of countersunk holes on the bottom face. These holes are used to attach the cleats you'll work on next.

Cleats. I cut the cleats to size and drilled stopped pilot holes for the lag screws that serve as wheel axles. At this point, you can attach the two cleats to the base with glue and screws.

Wheel Blocking. The two pieces of wheel blocking come next. They're shown in Figure 2 and look like the fenders on an automobile. I cut the rough blanks to size and then drilled the holes for the levelers. A hole saw makes it easy to rough out the cutout around the wheels. The band saw makes quick work of completing the shape.

After a little sanding, apply glue and clamp the wheel blocking to the base and cleats. You'll want to make sure the top edges are flush with the cleats as you apply clamping pressure.

Final Details. The last few details involve rounding over the top corners and then installing the hardware. To round over the corners, I turned to the router table. Flip the base upside down to rout the ½" roundover illustrated in Figure 2a.

Figures 1 and 2 show you how the wheels and levelers are installed. After applying a clear finish, you can attach the base to your drill press. I used a pair of lag screws to do this.

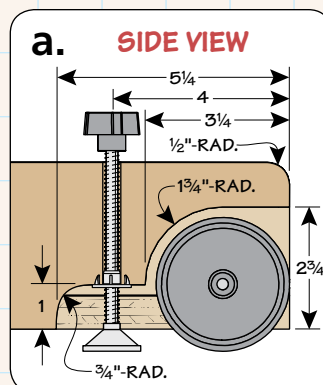
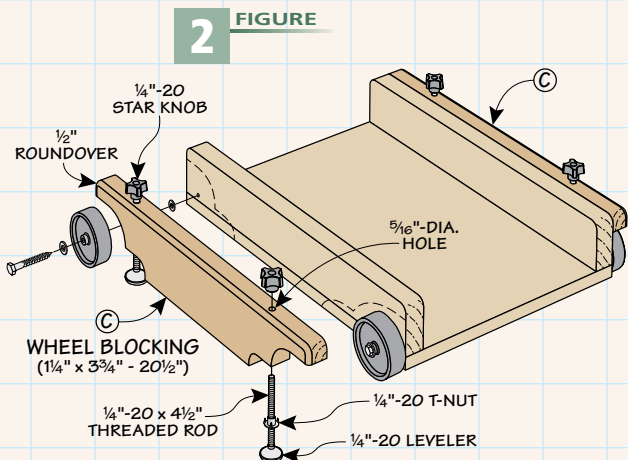
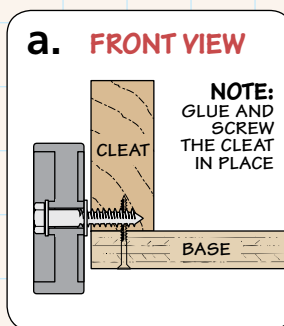
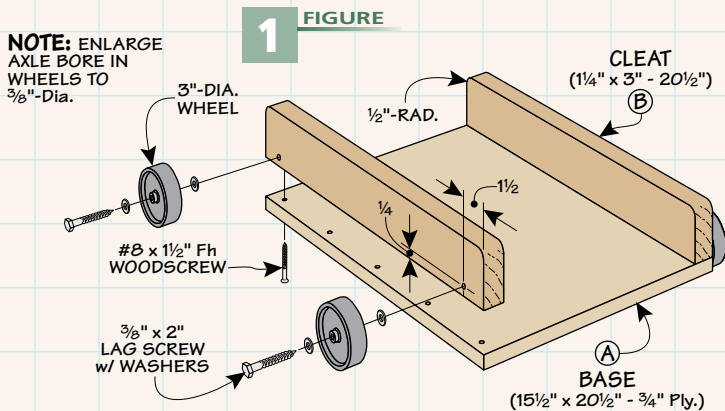

storage cabinet Base

NOTE: SEE PHOTO PAGE 2

FIGURE 3

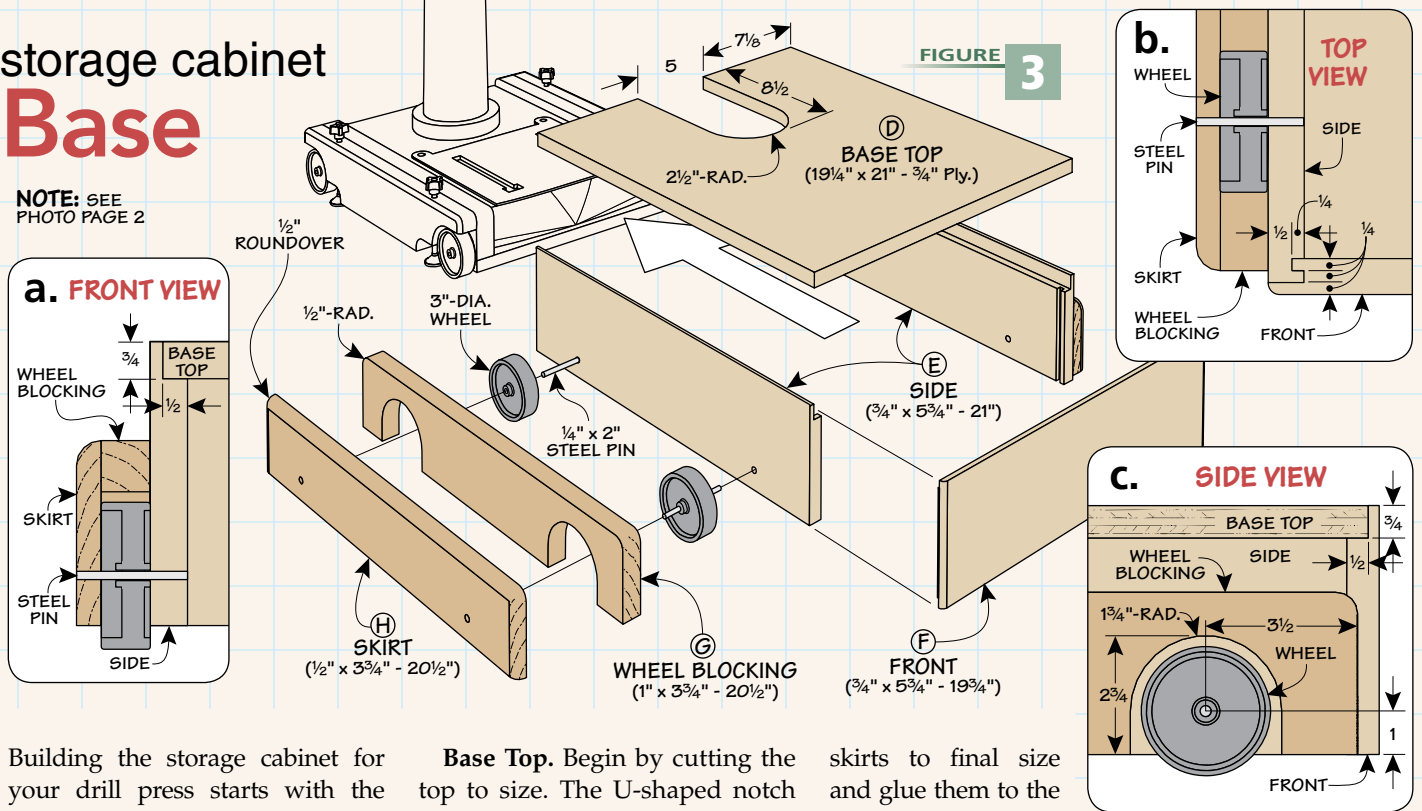

Building the storage cabinet for your drill press starts with the base. You'll find the construction pretty similar to the mobile base on the previous page. It's basically a box with wheels that fits like a glove over the mobile base.

The details of the construction are shown in Figure 3 above. A three-sided box is built with a base top, two sides, and a front. The wheels and blocking are sandwiched between outer skirts and the sides of the base. The wheels are attached with steel pins that serve as axles.

Base Top. Begin by cutting the top to size. The U-shaped notch that wraps around the column can be cut with a jig saw and sanded smooth.

Side Assemblies. In order to drill the holes for the steel axles easily and more accurately, I worked on the side assemblies next. This involves cutting the sides to size and rabbeting the top edge for attaching the base.

To make the wheel blocking, I used a hole saw to make the cut-out that surrounds the wheels. With that done, you can cut the

skirts to final size and glue them to the wheel blocking (Figure 3). After the glue dries, head to the router table to round over the edges with a $\frac{1}{2}$ " radius, as shown in Figures 3 and 3a.

Glue this sub-assembly to the sides then drill the axle holes. The last piece to cut is the front. It's rabbeted along the top and ends to join with the top of the base and sides.

After assembling the base, you can install the wheels with steel pins epoxied in place.

Materials & Hardware

MOBILE BASE

A Base (1)	$15\frac{1}{2} \times 20\frac{1}{2} - \frac{3}{4}$ Ply.
B Cleat (2)	$1\frac{1}{4} \times 3 - 20\frac{1}{2}$
C Wheel Blocking (2)	$1\frac{1}{4} \times 3\frac{3}{4} - 20\frac{1}{2}$

STORAGE CABINET

D Base Top (1)	$19\frac{1}{4} \times 21 - \frac{3}{4}$ Ply.
E Sides (2)	$\frac{3}{4} \times 5\frac{3}{4} - 21$
F Front (1)	$\frac{3}{4} \times 5\frac{3}{4} - 19\frac{3}{4}$
G Wheel Blocking (2)	$1 \times 3\frac{3}{4} - 20\frac{1}{2}$
H Skirts (2)	$\frac{1}{2} \times 3\frac{3}{4} - 20\frac{1}{2}$
I Top/Bottom (2)	$12\frac{3}{4} \times 19\frac{1}{4} - \frac{3}{4}$ Ply.
J Sides (2)	$12\frac{3}{4} \times 21 - \frac{3}{4}$ Ply.
K Back (1)	$19\frac{1}{4} \times 20\frac{1}{2} - \frac{3}{4}$ Ply.
L Sm. Drawer Sides (4)	$\frac{1}{2} \times 2\frac{1}{4} - 11$
M Sm. Drawer Frts./Backs (4)	$\frac{1}{2} \times 2\frac{1}{4} - 16\frac{3}{4}$
N Sm. False Fronts (2)	$18\frac{1}{8} \times 2\frac{15}{16} - \frac{3}{4}$ Ply.
O Med. Drawer Sides (2)	$\frac{1}{2} \times 4\frac{7}{8} - 11$
P Med. Drawer Frts./Backs (2)	$\frac{1}{2} \times 4\frac{7}{8} - 16\frac{3}{4}$

Q Med. False Front (1)	$18\frac{1}{8} \times 5\frac{7}{16} - \frac{3}{4}$ Ply.
R Large Drawer Sides (2)	$\frac{1}{2} \times 7\frac{1}{4} - 11$
S Lg. Drawer Fronts/Backs (2)	$\frac{1}{2} \times 7\frac{1}{4} - 16\frac{3}{4}$
T Large False Front (1)	$18\frac{1}{8} \times 7\frac{7}{8} - \frac{3}{4}$ Ply.
U Drawer Bottoms (4)	$10\frac{1}{2} \times 16\frac{3}{4} - \frac{1}{4}$ Hdbd.
V Tops/Bottoms (4)	$7\frac{3}{8} \times 8 - \frac{3}{4}$ Ply.
W Sides (4)	$7\frac{3}{8} \times 21 - \frac{3}{4}$ Ply.
X Backs (2)	$8 \times 20\frac{1}{2} - \frac{3}{4}$ Ply.
Y Shelves (4)	$7\frac{1}{8} \times 8 - \frac{3}{4}$ Ply.
Z Shelf Rails (4)	$\frac{3}{8} \times 1\frac{1}{4} - 7$
AA Cabinet Top (1)	$20\frac{1}{4} \times 21\frac{3}{4} - \frac{3}{4}$ Ply.

TABLE & FENCE

BB Base (1)	$12 \times 30 - \frac{3}{4}$ Ply.
CC Top (2)	$12 \times 13\frac{1}{16} - \frac{1}{4}$ Hdbd.
DD Insert (1)	$5 \times 12 - \frac{1}{4}$ Hdbd.
EE Fence (1)	$2\frac{1}{2} \times 30 - 1\frac{1}{2}$ Ply.
FF Fence Face (1)	$2\frac{1}{2} \times 30 - \frac{1}{4}$ Hdbd.

- (8) 3" Wheels
- (4) $\frac{3}{8}$ " x 2" Lag Screws
- (10) $\frac{1}{4}$ " Washers
- (6) $\frac{1}{4}$ "-20 Star Knobs
- (4) $\frac{1}{4}$ "-20 x 1"-dia. Levelers
- (4) $\frac{1}{4}$ "-20 x $4\frac{1}{2}$ " Threaded Rod
- (4) $\frac{1}{4}$ "-20 T-Nuts
- (10) #8 x $1\frac{1}{2}$ " Fh Woodscrews
- (4) $\frac{1}{4}$ " x $2\frac{1}{4}$ " Steel Rod
- (4 pr.) 10" Full-Ext. Drawer Slides w/Screws
- (16) #6 x $\frac{3}{4}$ " Fh Woodscrews
- (22) #8 x $1\frac{1}{4}$ " Fh Woodscrews
- (4) Sash Pulls
- (2) $\frac{1}{4}$ "-20 x $3\frac{1}{4}$ " Flange Bolts
- (4) $\frac{5}{16}$ "-18 T-Nuts
- (4) $\frac{5}{16}$ " Washers
- (4) $\frac{5}{16}$ "-18 Hex Bolts (to attach table)

adding Storage

The storage cabinet features a handy bank of drawers. However, the depth of the drawers is limited by the drill press column. So that the space on either side of the column isn't wasted, I added a pair of cubbies to provide useful, additional storage.

Drawer Case. Construction starts with the drawer case. Figure 4 shows how it goes together. I started by cutting all five parts to size. The back edges of the top and bottom are rabbeted to join with the back panel. Three edges of the side panels are rabbeted, as well. You can see what I mean in Figures 4a and 4b.

The assembly of the case is pretty straightforward. A little glue and clamps get the job done. Once the glue dries, you can attach the case to the base.

Drawers. As you can see in Figure 5, there are four drawers to build in three different heights. The joinery is all the same and the part sizes are identical except for the width.

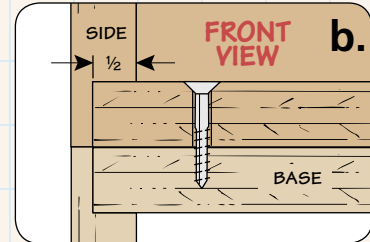
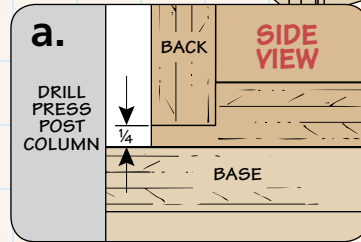
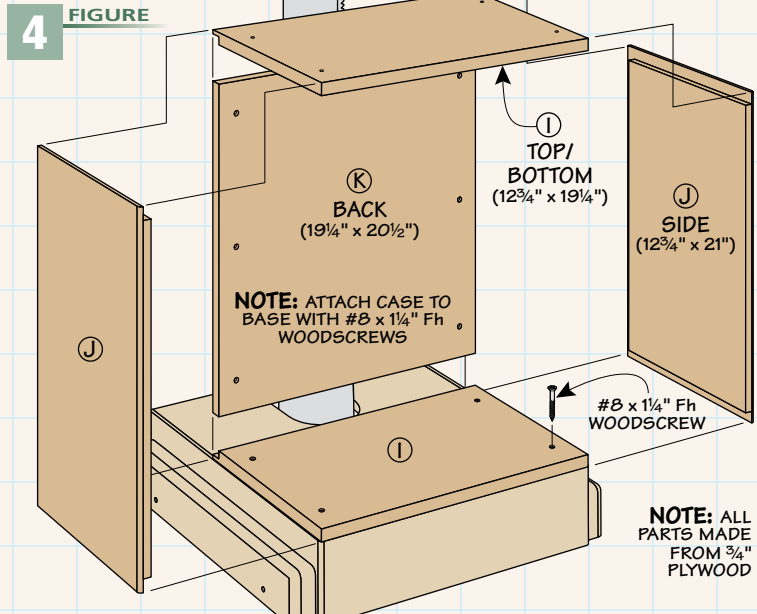

5 FIGURE

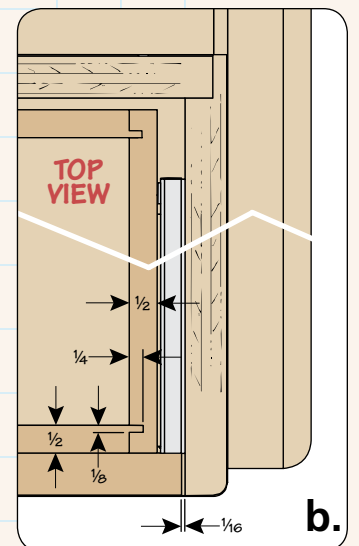
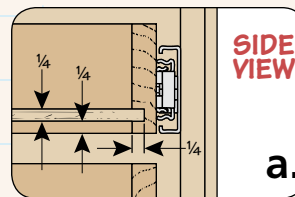
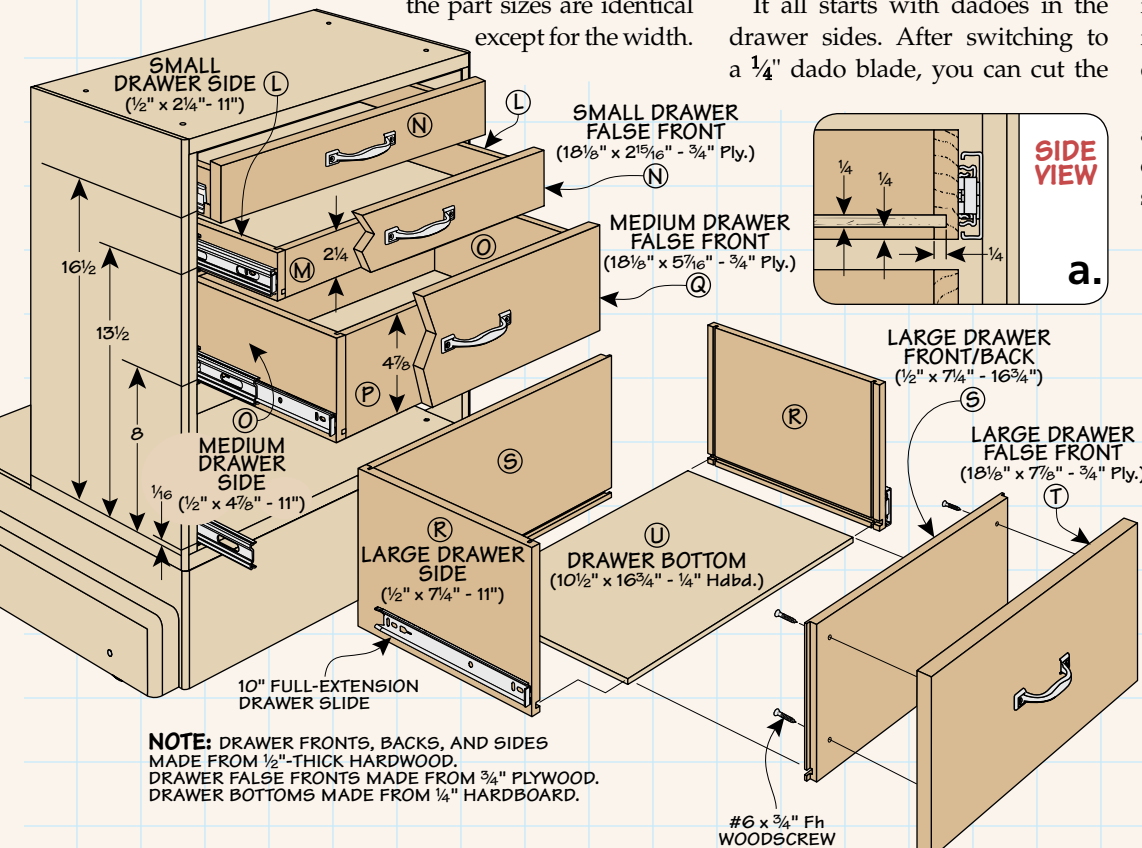

The drawers are assembled with strong tongue and dado joinery. So once all the sides, fronts and backs are cut to size, you can set up an assembly line to cut all the parts.

It all starts with dados in the drawer sides. After switching to a 1/4" dado blade, you can cut the

grooves for the drawer bottoms before moving on.

Next, bury a dado blade in an auxiliary rip fence to cut the rabbets on the ends of the drawer fronts and backs. These rabbets form the tongues that fit into the dados in the drawer sides.

After cutting the bottoms to size and gluing up all the drawers, you can mount them on full-extension slides, as shown in Figure 5.

Then cut and fit the false fronts and install the pulls.

Storage Cubbies. The storage cubbies are next. They fit behind the case flush with the sides.

The construction of the cubbies is similar to the drawer case. The details are illustrated in Figure 6. The only difference in the construction is a dado cut in the sides and back to house a fixed shelf.

After cutting the shelf to size, you can assemble the case. One more detail to add is the pair of shelf rails. These are simply glued in place before you attach the cubbies to the cabinet.

Finally, a Top. The last piece of the puzzle is the large cabinet top you see in Figure 7. Like the base, it wraps around the drill press column and provides additional worksurface. Two recesses on either side keep drill bits and other small items from rolling off onto the floor.

As with the base of the cabinet, you'll cut the top to size and cut out the U-shaped notch with a jig saw. After a little sanding, you can round over all the edges and get set up to rout the recesses.

Routing the Recesses. To create the recesses on the top, I used a technique detailed in the lower

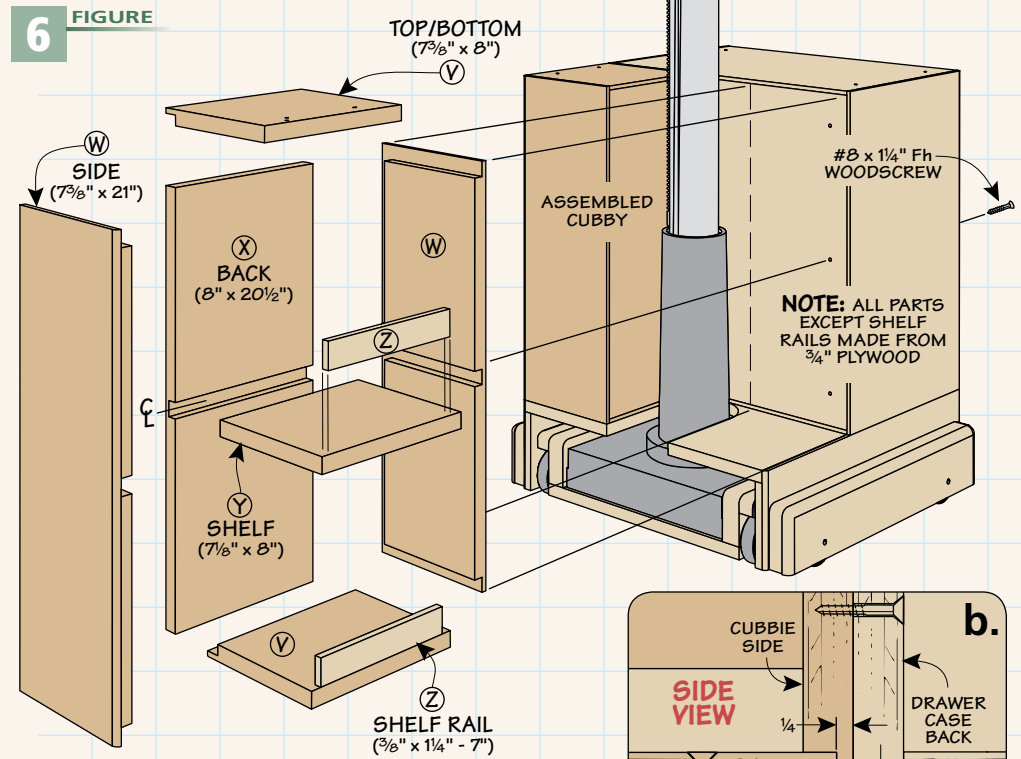

right box. I made a template with an opening sized for the recess.

To rout the recess, I used a bowl and tray bit in a router with a large auxiliary base. The bit creates rounded inside corners while leaving a flat bottom.

You'll want to rout in a clockwise direction with the bearing of the bit in contact with the inside edge of the template. This creates the outline of the recess. Then it's

a simple matter of removing the remaining waste with several passes of the router across the recess.

Finish Up. Now you're ready to attach the top with screws from inside the drawer cabinet and cubbies, as shown in Figure 7. Apply a clear finish before rolling the cabinet into place and putting it to good use.

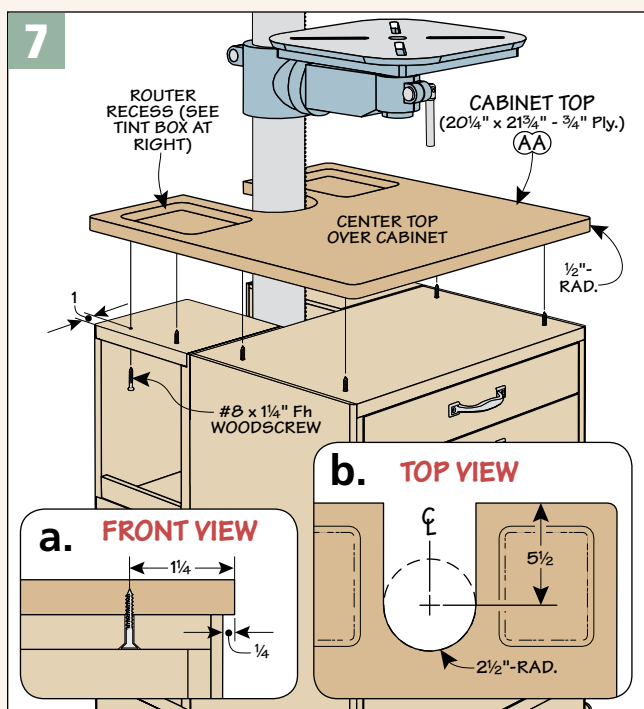
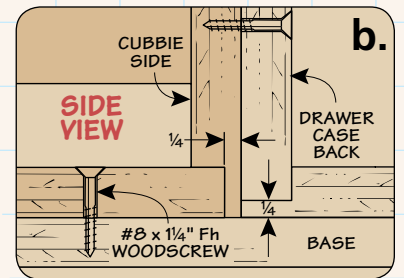

Router Template

You can make a template like the one shown below by assembling the four sides with pocket hole joinery. This technique allows you to size the opening perfectly for the task. Then, rout out the waste.

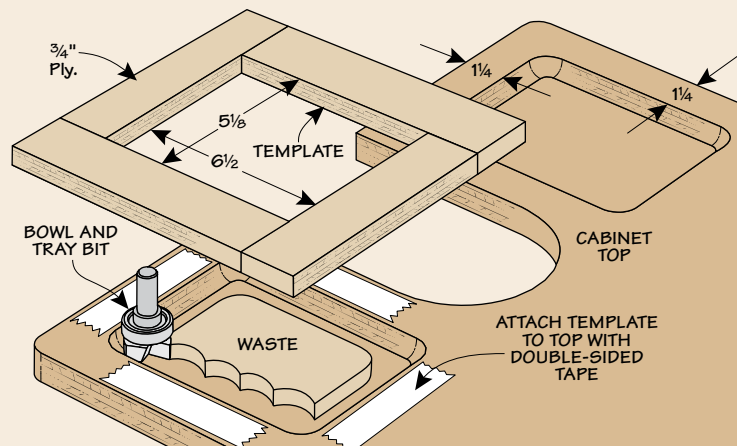
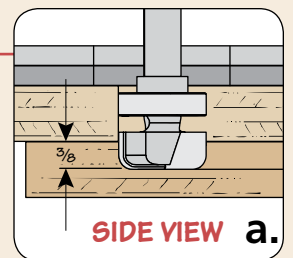



drill press Table & Fence

An auxiliary table and an adjustable fence are the two best improvements you can make to a “bare bones” drill press. I thought the combo shown above was a perfect complement to the mobile base and storage cabinet. The table shown here has been in use for a lot of years in my shop and is one of my favorites.

Let’s start with the table. It’s much larger than the metal drill press table it’s attached to. So it

offers plenty of support when working with long pieces.

The table also lays the groundwork for an adjustable fence. To allow positioning of the fence quickly and accurately, it slides along two T-shaped slots in the table. And a pair of flange bolts and knobs lock it in place.

$\frac{3}{4}$ ”-thick plywood on the bottom. And a top layer of $\frac{1}{4}$ ” hardboard creates a smooth, durable worksurface.

There’s also another advantage to this double-layered assembly. The top layer has a removable insert, as shown in Figure 8. When this insert gets chewed up with use, simply slide it in or out to expose a fresh drilling surface. Or replace it with a new insert.

Base. I started on the table by making the plywood base (Figure 8). To form the wide portion of the T-slots, you’ll need to cut two dadoes in the base, as in Figure 8a. Later, each of these dadoes will accept the head of a flange bolt that guides the fence in the T-slot.

Install T-Nuts. The next step is to install T-nuts that are used to attach the base to the metal drill press table. To locate the holes for these T-nuts, start by setting the base on the drill press table. Then, after marking the location of the holes from underneath the

TABLE

The table is made up of two layers. For rigidity, there’s a layer of

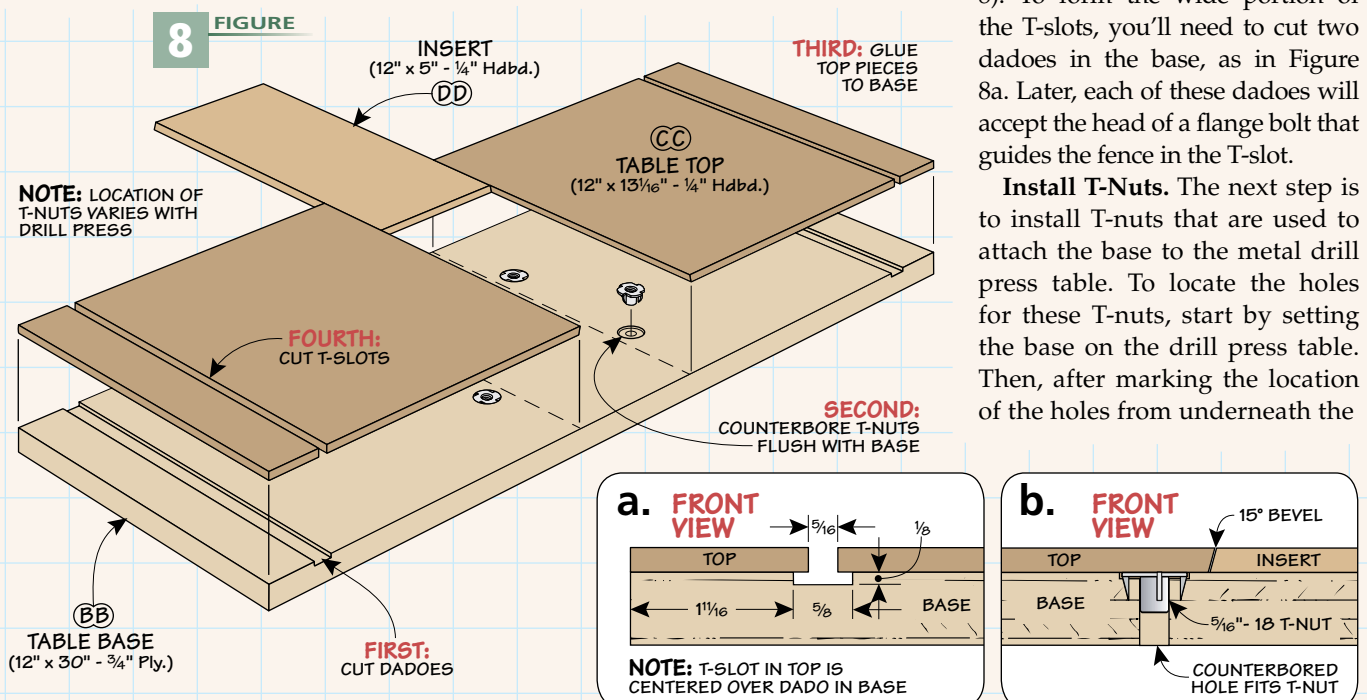

table, drill counterbored through holes and install the T-nuts.

Top. Now you can concentrate on the top of the table. It consists of two top pieces and the insert, as illustrated in Figure 8 on the previous page and Figure 10 below. Note: It's best to cut oversize top pieces and trim them flush later.

The insert is captured in a dovetail-shaped opening in the top of the table. This opening is formed by cutting a bevel on the inside edge of the top pieces, as shown in Figure 8b on the previous page. To prevent the insert from binding, the beveled edges of the top pieces need to be parallel to each other. A simple solution is to use a spacer between them when gluing on the pair of top pieces.

After trimming the edges flush, you can complete the second half of the T-slots. This is just a matter of cutting dadoes in the top pieces (Figure 8a, page 7).

Now all that's left is to cut an insert to fit the opening in the table. To do this, you'll need to bevel both edges of the insert. While you're at it, it's a good idea to make several extra inserts so you'll have a few spares.

FENCE

After attaching the drill press table with bolts, the next step is to add the fence. The thing I like best

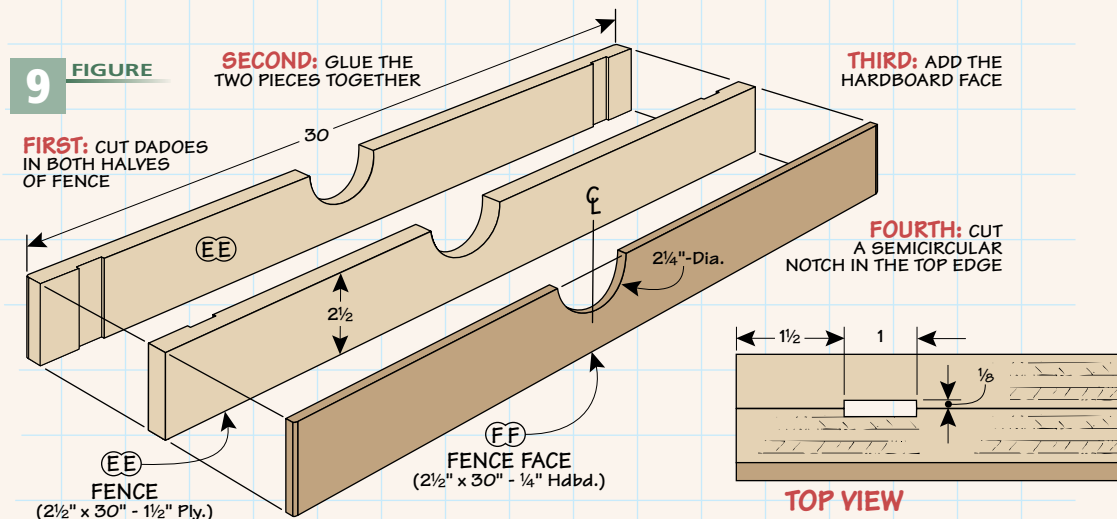

about this fence is you can adjust it without having to coax first one end and then the other. The reason has to do with a narrow slot in each end of the fence. These slots form openings for the flange bolts that guide the fence.

Why not just drill holes for the bolts? After all, it would be quicker. The only problem is if you don't move both ends of the fence the same amount when making an adjustment, the bolts would jam in the holes and cause the fence to bind. But the slots provide clearance for the bolts. So even if both ends of the fence aren't perfectly aligned, it still slides nice and smooth.

Fence Pieces. To make the fence, start by cutting the two plywood fence pieces, as illustrated in Figure 9. The slot for the flange bolts

is formed by first cutting a pair of shallow dadoes in each piece, then assembling these so the dadoes align and form a slot for the bolt. The margin photo shows how to do this using a waxed key. After this assembly dries, you can add the hardboard face.

Notch. Before installing the fence, I cut a semicircular notch in the top edge. The details are shown in Figure 9. This notch provides clearance for the chuck when using shorter drill bits. I used a Forstner bit to drill the notch and then sanded it smooth.

Attach Fence. Now all that's left is to attach the fence to the table. After slipping the flange bolts in place, set the fence down over them. Tightening knobs on the ends of the bolts locks the fence in place.

▲ Glueup Tip. A waxed "key" ensures proper alignment when gluing up the fence pieces.

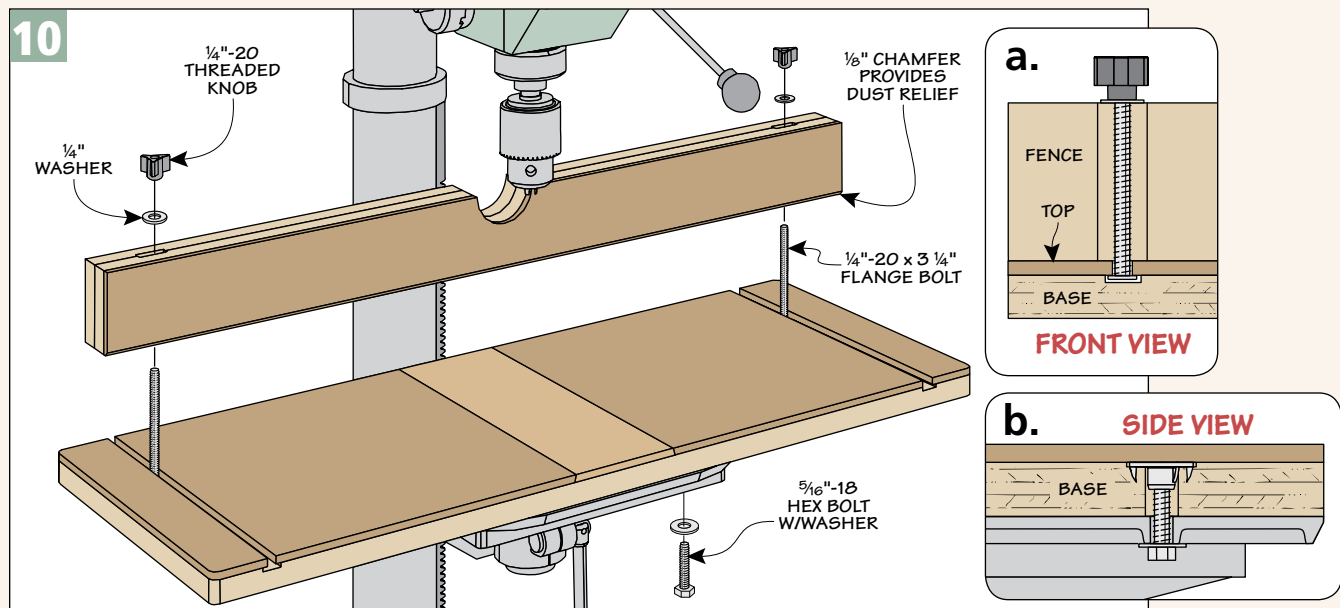

3-in-1 Drill Press Upgrade

Materials List

MOBILE BASE

A	Base (1)	15½ x 20½ - ¾ Ply.
B	Cleat (2)	1¼ x 3 - 20½
C	Wheel Blocking (2)	1¼ x 3¾ - 20½

STORAGE CABINET

D	Base Top (1)	19¼ x 21 - ¾ Ply.
E	Sides (2)	¾ x 5¾ - 21
F	Front (1)	¾ x 5¾ - 19¾
G	Wheel Blocking (2)	1 x 3¾ - 20½
H	Skirts (2)	½ x 3¾ - 20½
I	Top/Bottom (2)	12¾ x 19¼ - ¾ Ply.
J	Sides (2)	12¾ x 21 - ¾ Ply.
K	Back (1)	19¼ x 20½ - ¾ Ply.
L	Sm. Drawer Sides (4)	½ x 2¼ - 11
M	Sm. Drawer Frts./Backs (4)	½ x 2¼ - 16¾
N	Sm. False Fronts (2)	18⅞ x 2⅝ - ¾ Ply.
O	Med. Drawer Sides (2)	½ x 4⅞ - 11
P	Med. Drawer Frts./Backs (2)	½ x 4⅞ - 16¾

Q	Med. False Front (1)	18⅞ x 5⅞ - ¾ Ply.
R	Large Drawer Sides (2)	½ x 7¼ - 11
S	Lg. Drawer Fronts/Backs (2)	½ x 7¼ - 16¾
T	Large False Front (1)	18⅞ x 7⅞ - ¾ Ply.
U	Drawer Bottoms (4)	10½ x 16¾ - ¼ Hdbd.
V	Tops/Bottoms (4)	7⅞ x 8 - ¾ Ply.
W	Sides (4)	7⅞ x 21 - ¾ Ply.
X	Backs (2)	8 x 20½ - ¾ Ply.
Y	Shelves (4)	7⅞ x 8 - ¾ Ply.
Z	Shelf Rails (4)	¾ x 1¼ - 7
AA	Cabinet Top (1)	20¼ x 21¾ - ¾ Ply.

TABLE & FENCE

BB	Base (1)	12 x 30 - ¾ Ply.
CC	Top (2)	12 x 13⅞ - ¼ Hdbd.
DD	Insert (1)	5 x 12 - ¼ Hdbd.
EE	Fence (1)	2½ x 30 - 1½ Ply.
FF	Fence Face (1)	2½ x 30 - ¼ Hdbd.

- 8) 3" Wheels
- (4) ⅜" x 2" Lag Screws
- (10) ¼" Washers
- (6) ¼"-20 Star Knobs
- (4) ¼"-20 x 1" -dia. Levelers
- (4) ¼"-20 x 4½" Threaded Rod
- (4) ¼"-20 T-Nuts
- (10) #8 x 1½" Fh Woodscrews
- (4) ¼" x 2¼" Steel Rod
- (4 pr.) 10" Full-Ext. Drawer Slides w/Screws
- (16) #6 x ¾" Fh Woodscrews
- (22) #8 x ¼" Fh Woodscrews
- (4) Sash Pulls
- (2) ¼"-20 x 3¼" Flange Bolts
- (4) ⅝"-18 T-Nuts
- (4) ⅝" Washers
- (4) ⅝"-18 Hex Bolts (to attach table)

Cutting Diagram

1¼" x 8" - 72" MAPLE (6.0 Bd. Ft.)

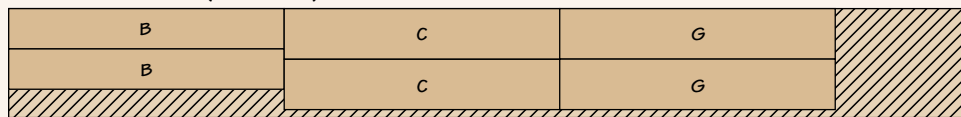

NOTE: PLANE PARTS 'G' TO 1" THICK

¾" x 8" - 72" MAPLE (4.0 Bd. Ft.)



½" x 7½" - 96" MAPLE (5.0 Bd. Ft.)

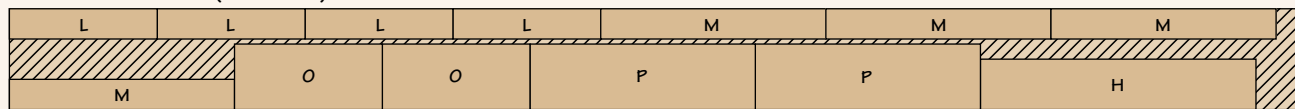

½" x 7½" - 96" MAPLE (5.0 Bd. Ft.)

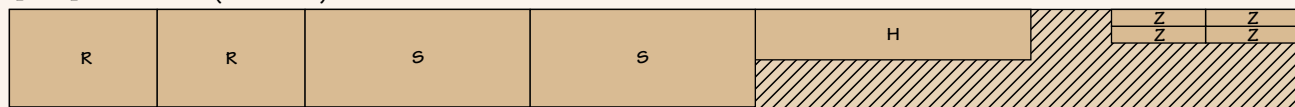

NOTE: PLANE PARTS 'Z' TO ⅜" THICK

Cutting Diagram cont.

48" x 96" - 3/4" BIRCH PLYWOOD

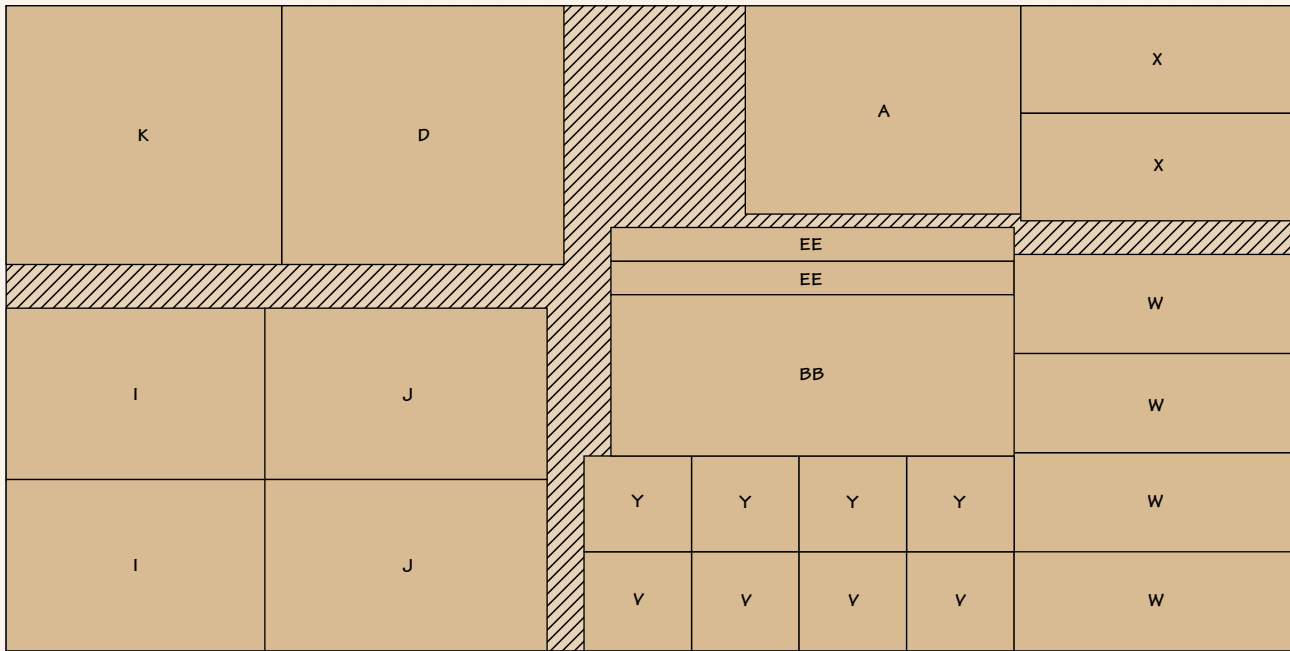

48" x 24" - 3/4" BIRCH PLYWOOD

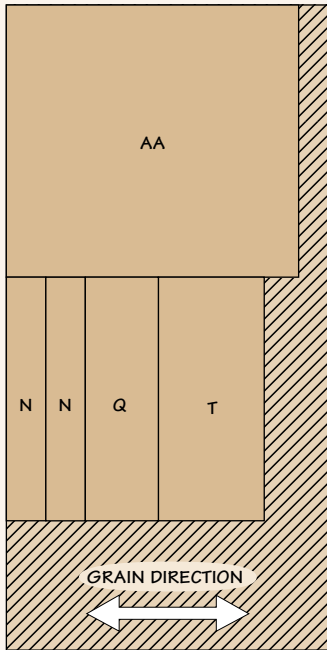

48" x 48" - 1/4" HARDBOARD

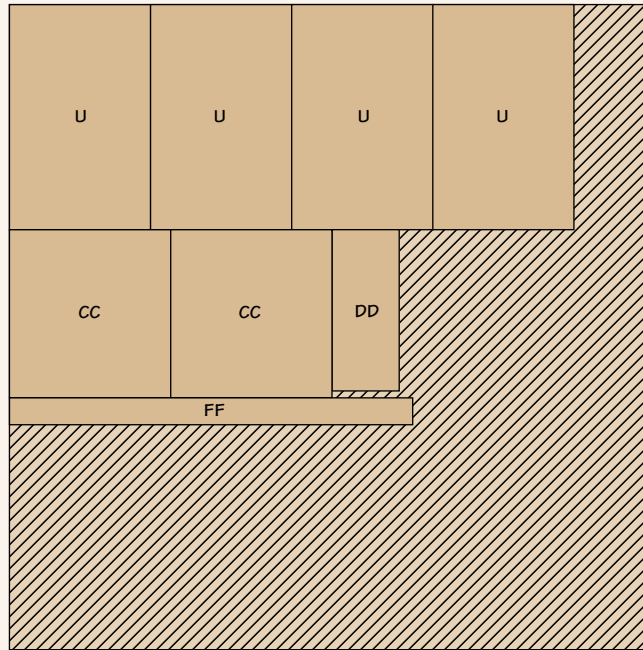

**MAIL
ORDER
SOURCES**

Woodsmith Store
800-444-7527

McMaster-Carr
630-833-0300
mcmaster.com

Rockler
800-279-4441
rockler.com

Project Sources

For the 3-in-1 drill press upgrade, you can go online to *McMaster-Carr* to purchase the 1"-dia. levelers (6103K65) and the 3"-dia. wheels (2781T72). You can find the 10" full extension slides (61440) at *Rockler*.

Manufacturers and retailers will periodically redesign or discontinue some of their items. So you'll want to gather all the hardware, supplies, and tools you need before you get started. It's easy to adjust dimensions or drill different-sized holes to suit your hardware.