



## Installation Instructions

# DRO Retrofit Kit for 15" and 20" Planers

For Jet Planer Models: JWP-15CS, JWP-208

For Powermatic Planer Models: 15, 15S, 208, 209, 209HH



*DRO shown on Model JWP-15CS Planer*

### JET

427 New Sanford Road  
LaVergne, Tennessee 37086  
Ph.: 800-274-6848  
[www.jettools.com](http://www.jettools.com)

**Part No. M-708520**  
Revision A2 02/2014  
Copyright © 2014 JET

# Warranty and Service

JET warrants every product it sells against manufacturers' defects. If one of our tools needs service or repair, please contact Technical Service by calling 1-800-274-6846, 8AM to 5PM CST, Monday through Friday.

## Warranty Period

The general warranty lasts for the time period specified in the literature included with your product or on the official JET branded website.

- JET products carry a limited warranty which varies in duration based upon the product. (See chart below)
- Accessories carry a limited warranty of one year from the date of receipt.
- Consumable items are defined as expendable parts or accessories expected to become inoperable within a reasonable amount of use and are covered by a 90 day limited warranty against manufacturer's defects.

## Who is Covered

This warranty covers only the initial purchaser of the product from the date of delivery.

## What is Covered

This warranty covers any defects in workmanship or materials subject to the limitations stated below. This warranty does not cover failures due directly or indirectly to misuse, abuse, negligence or accidents, normal wear-and-tear, improper repair, alterations or lack of maintenance.

## Warranty Limitations

Woodworking products with a Five Year Warranty that are used for commercial or industrial purposes default to a Two Year Warranty. Please contact Technical Service at 1-800-274-6846 for further clarification.

## How to Get Technical Support

Please contact Technical Service by calling 1-800-274-6846. **Please note that you will be asked to provide proof of initial purchase when calling.** If a product requires further inspection, the Technical Service representative will explain and assist with any additional action needed. JET has Authorized Service Centers located throughout the United States. For the name of an Authorized Service Center in your area call 1-800-274-6846 or use the Service Center Locator on the JET website.

## More Information

JET is constantly adding new products. For complete, up-to-date product information, check with your local distributor or visit the JET website.

## How State Law Applies

This warranty gives you specific legal rights, subject to applicable state law.

## Limitations on This Warranty

JET LIMITS ALL IMPLIED WARRANTIES TO THE PERIOD OF THE LIMITED WARRANTY FOR EACH PRODUCT. EXCEPT AS STATED HEREIN, ANY IMPLIED WARRANTIES OF MERCHANTABILITY AND FITNESS FOR A PARTICULAR PURPOSE ARE EXCLUDED. SOME STATES DO NOT ALLOW LIMITATIONS ON HOW LONG AN IMPLIED WARRANTY LASTS, SO THE ABOVE LIMITATION MAY NOT APPLY TO YOU.

JET SHALL IN NO EVENT BE LIABLE FOR DEATH, INJURIES TO PERSONS OR PROPERTY, OR FOR INCIDENTAL, CONTINGENT, SPECIAL, OR CONSEQUENTIAL DAMAGES ARISING FROM THE USE OF OUR PRODUCTS. SOME STATES DO NOT ALLOW THE EXCLUSION OR LIMITATION OF INCIDENTAL OR CONSEQUENTIAL DAMAGES, SO THE ABOVE LIMITATION OR EXCLUSION MAY NOT APPLY TO YOU.

JET sells through distributors only. The specifications listed in JET printed materials and on official JET website are given as general information and are not binding. JET reserves the right to effect at any time, without prior notice, those alterations to parts, fittings, and accessory equipment which they may deem necessary for any reason whatsoever. JET® branded products are not sold in Canada by JPW Industries, Inc.

## Product Listing with Warranty Period

90 Days – Parts; Consumable items; Light-Duty Air Tools
1 Year – Motors; Machine Accessories; Heavy-Duty Air Tools; Pro-Duty Air Tools
2 Year – Metalworking Machinery; Electric Hoists, Electric Hoist Accessories
5 Year – Woodworking Machinery
Limited Lifetime – JET Parallel clamps; VOLT Series Electric Hoists; Manual Hoists; Manual Hoist Accessories; Shop Tools; Warehouse & Dock products; Hand Tools

NOTE: JET is a division of JPW Industries, Inc. References in this document to JET also apply to JPW Industries, Inc., or any of its successors in interest to the JET brand.

# Table of Contents

Warranty and Service .....	2
Table of Contents .....	3
Unpacking .....	3
Shipping Contents.....	3
Installation on 15" Planer .....	4
Alignment.....	4
Installation on a 20" Planer .....	5
Reversing the Lock Knob .....	5
DRO Installation.....	5
Alignment.....	6
Maintenance .....	6
Functions of the Digital Scale.....	7
Setting The DRO.....	7
Parts .....	8
Exploded View .....	8
Parts List.....	8
Ordering Replacement Parts.....	8

## Unpacking

Open the Retrofit Kit box and check for shipping damage. Report any damage immediately to your distributor and shipping agent. Do not discard any shipping material until the Retrofit Kit is assembled and running properly.

Compare the contents of your container with the following parts list to make sure all parts are intact. Missing parts, if any, should be reported to your distributor. Read this manual thoroughly for correct assembly procedures.

### Shipping Contents

- 1 Scale (A)
- 1 Upper Mounting Bracket (B)
- 1 Lower Mounting Bracket (C)
- 1 Spare Battery (not shown)

#### Mounting Hardware for 15/20: Planers

- 1 M6x30 Socket Head Cap Screw for 15" Planer (D)
- 1 M8x30 Socket Head Cap Screw for 20" Planer (E)
- 1 M10x30 Socket Setscrew (K)
- 1 M10 Hex Nut (L)
- 1 M6 Washer for 15" Planer (F)
- 1 M8 Washer for 20" Planer (G)
- 1 M4x6 Screw (H)
- 1 M4 Washer (J)

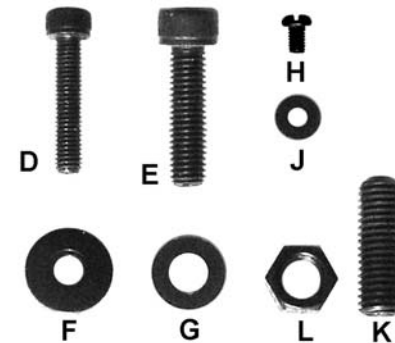
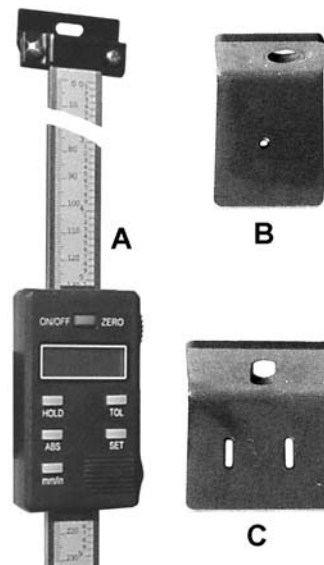

Mounting Hardware for 15/20" Planers

## Installation on 15" Planer

Refer to Figures 1 and 2.

1. Lower the planer table by rotating the *handwheel* (A) counterclockwise. This will provide unhindered access under the gearbox during installation.
2. Remove *setscrew* (B) from the head casting and the lower *socket head cap screw* (C) in the table casting with a 5mm hex wrench.
3. Replace the short setscrew in the head casting with the long *setscrew* (D) from the hardware kit. Do not over tighten.
4. Place the *upper bracket* (E) on the *setscrew* (D). Thread the *hex nut* (F) on the setscrew and secure just enough so the bracket can freely swivel.
5. Mount the *lower bracket* (K) on the table casting, securing it with the *washer* (H) and *socket head cap screw* (J) from the hardware kit and secure just enough so the bracket can freely swivel.
6. Locate the two *screws* (G) pre-assembled on the back of the *DRO* (L) and remove them with a cross-point screwdriver.
7. Secure the *DRO* (L) to the *lower bracket* (K) using the two *screws* (G) that were removed in the previous step. Do not tighten at this time.
8. Secure the top of the DRO (P) to the top *bracket* (E) using the small *washer* (O) and *screw* (N) from the hardware kit. Do not tighten at this time.
9. Proceed to the *Alignment* section.

### Alignment

1. Using line of sight, align the front face of the *scale* (M) with the front edge of the *right front post* (Q).
2. Tighten the *nut* (F) securing the *top bracket* (E) with a 14mm socket wrench.
3. Tighten the *socket head cap screw* (J) securing the *lower bracket* (K) with the 5mm hex wrench.
4. With a measuring device, adjust the top and bottom of the *scale* (M) to be the same distance from the *post* (Q).
5. Tighten three *screws* (N and G) securing the DRO to the top and lower brackets.



Figure 1

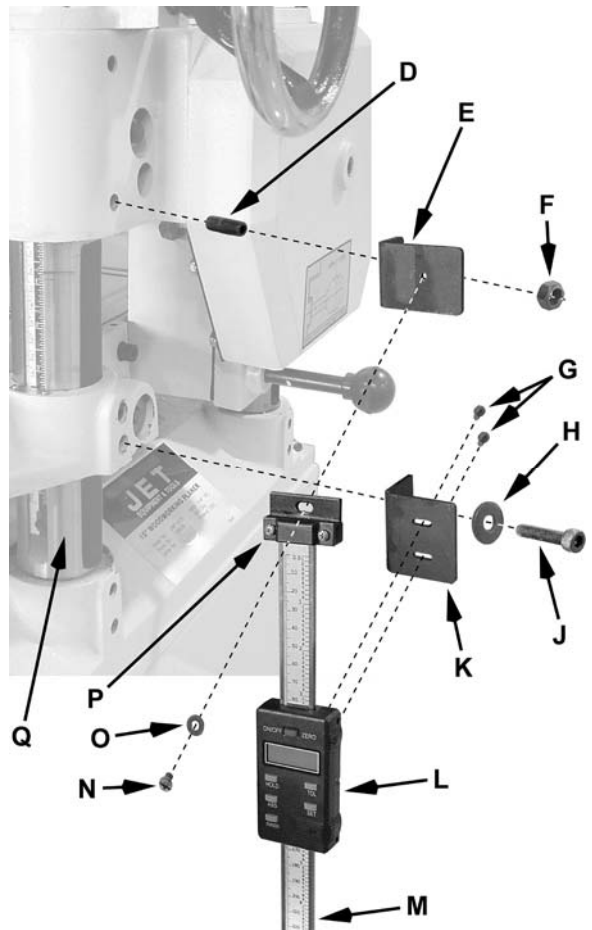

Figure 2

# Installation on a 20" Planer

## Reversing the Lock Knob

Referring to Figure 3:

The first step in the installation of the DRO is to reverse the table lock knob assembly so the *lock knob* (A), which is located on the right side of the table as shown in Figure 3, is moved to the left side.

Proceed as follows:

1. Remove the front *lock knob* (A) by turning counterclockwise.
2. Remove the unthreaded *lock bushing* (B).
3. The *bar lock* (F) is threaded and is screwed on to the *lock bolt* (bar – item D). Remove as one unit from the left side of the table and *insert into the right side* of the table. Make sure that the bevel on the *bar lock* (F) rests against the column.
4. Insert the unthreaded *lock bushing* (B) into the left side of the table, sliding it onto the protruding *lock bolt* (D). Make sure that the bevel on the *lock bushing* (B) rests against the column.
5. Screw the *lock knob* (A) clockwise onto the threaded end of the *lock bolt* (D) on the *left side* of the table. Tighten all the way (locked position), then turn about 1/2 turn counterclockwise to unlock.
6. Repeat steps 1–4 for the rear lock knob assembly.

## DRO Installation

1. Lower the planer table by rotating the *handwheel* (A) counterclockwise. This will provide unhindered access under the gearbox during installation.
2. With a 3mm hex wrench, unscrew the *hex cap screw* (B) securing the *pointer* (C) and remove both.
3. Using a cross-point screwdriver, unscrew the two *screws* (D) securing the *scale* (E) to the head casting and remove both.
4. In the head casting, remove the short *setscrew* (F) using a 5 mm hex wrench.
5. In the table casting, remove the lower *hex cap screw* (G) using a 6mm hex wrench.

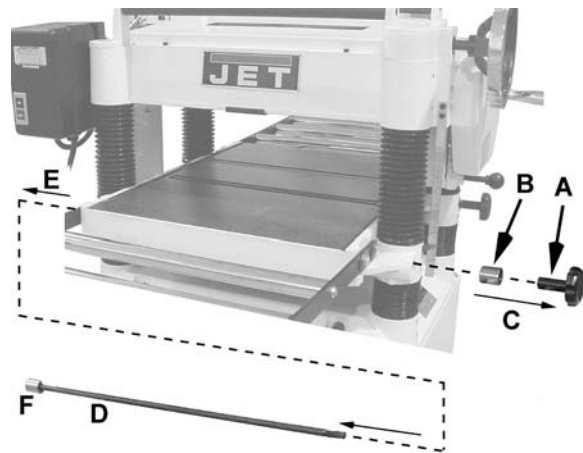

Figure 3

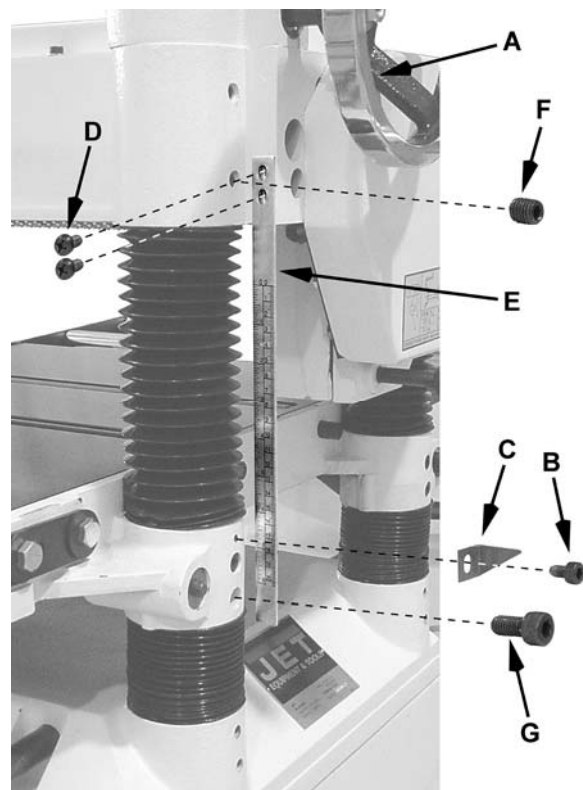

Figure 4

Referring to Figure 5:

6. Insert the long *setscrew* (A) from the hardware kit into the head casting. Secure with a 5mm hex wrench, but do not over-tighten.
7. Place the *upper bracket* (B) on the *setscrew* (A). Thread the *hex nut* (C) on the *setscrew* and secure just enough so the bracket can freely swivel
10. Mount the *lower bracket* (D) on the table casting, securing it with the *washer* (E) and *socket head cap screw* (F) from the hardware kit just enough so the bracket can freely swivel.
11. Locate the two *screws* (G) pre-assembled on the back of the *DRO* (H) and remove them with a cross-point screwdriver.
12. Secure the *DRO* (H) to the *lower bracket* (D) using the two *screws* (G) that were removed in the previous step. Do not tighten at this time.
13. Secure the top of the DRO (J) to the top *bracket* (B) using the small *washer* (K) and *screw* (L) from the hardware kit. Do not tighten at this time.

## Alignment

Referring to Figure 5:

6. Using line of sight, align the front face of the *scale* (M) with the front edge of the *right front post* (N).
7. Tighten the *nut* (C) securing the *top bracket* (B) with a 14mm socket wrench.
8. Tighten the *socket head cap screw* (F) securing the *lower bracket* (D) with the 6mm hex wrench.
9. With a measuring device, adjust the top and bottom of the *scale* (M) to be the same distance from the *post* (N).
10. Tighten three *screws* (G and L) securing the DRO to the top and lower brackets.

## Maintenance

- ❑ Check occasionally that the screws holding the device to the planer are tight.
- ❑ Perform realignment if needed.

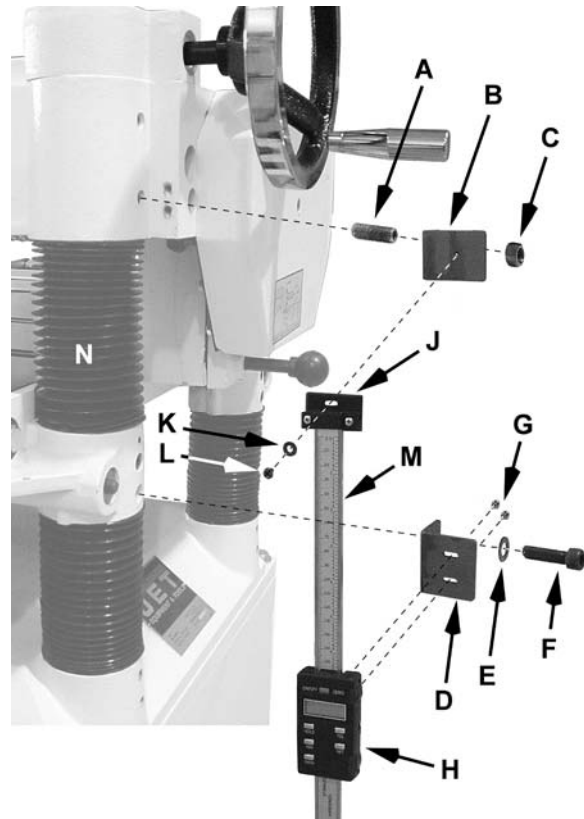

Figure 5

# Functions of the Digital Scale

Figure 6 identifies the parts of the digital scale. The button functions are discussed below, followed by a section giving practical examples of how to calibrate your settings, and how these functions can be used for daily planer operations.

Before using the device, wipe down the vertical scale with a dry, soft cloth. Do not use cleaning solutions. Do not allow any liquids (such as machine oil) to contact the body of the digital display. Keep the device clean.

This device uses a 1.5-volt battery cell (SR44 or G-13A). If it needs replacing, slide off the battery cover and insert the battery, with the positive pole of the battery facing out.

**Note:** After replacing a battery, the digital display setting defaults to zero and needs to be reset as described in the *Setting the DRO* section.

## ON/OFF

Press *ON/OFF* button no longer than 3 seconds to power on.

Press *ON/OFF* button at least 3 seconds to shut off the digital display.

## Setting The DRO

Setting the DRO sets the distance from the table to the cutterhead (*Absolute* measurement) which represents the thickness of the planed board.

1. Take a board of *arbitrary thickness*, plane it and measure the thickness with a caliper. Make note of this measurement for use below.
2. Without moving the table, press the SET button on the DRO – the indicator will flash “SET”.
3. Press and hold the SET button.  
Each digit will flash in turn. When the digit you want flashes, release the SET button.
4. Press SET button once (no longer than 1 second) and that digit will increase by one each time SET is pressed.

When finished:

5. Press and hold the SET button until indicator “SET” flashes,

6. Press SET again (no longer than 1 second). The indicator “SET” disappears and the value you just input is displayed on the LCD.

From this point on, any table movement will be based off this setting. The setting will be kept in the device’s memory, even when the digital display is turned off and only needs resetting after a battery has lost charge and needs replacing.

## Relative Mode

Periodically during planing operations, it may be desirable to display the amount of material to be removed from a previously planed board.

With a planer at the last thickness setting for that board:

1. Press ABS until “INC” appears. This toggles the DRO from *Absolute* to *Relative* mode.
2. Press the ON/OFF button for less than three seconds. The digital display resets to zero.

Raising the table will represent the additional material to be removed from a board from the previous setting.

3. To toggle back to *Absolute* mode, press ABS again.

**IMPORTANT:** Always place the digital display in *relative* (“INC”) mode before turning it off. If you turn it off while in *absolute* (“ABS”) mode, your absolute setting will default to zero.

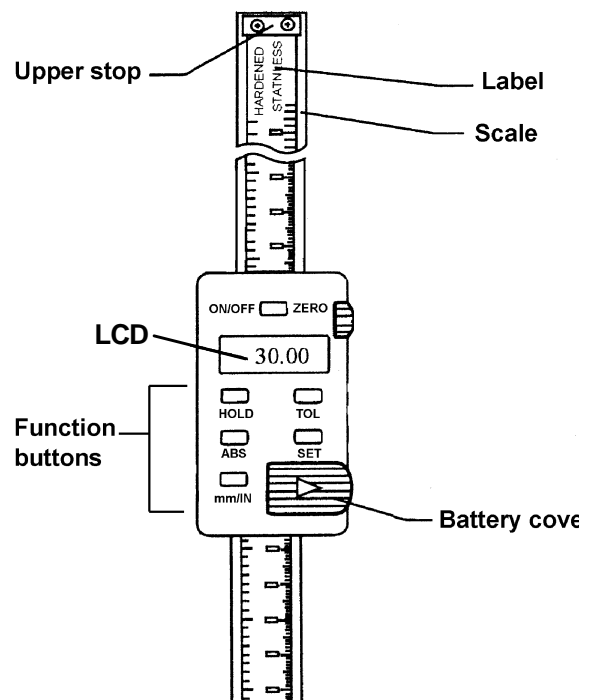

Figure 6

## MM/INCH

Pressing this button toggles back and forth between standard (inches) and metric (mm), and can be done at any time without affecting saved settings.

## HOLD

The *Hold* button is used to record a critical setting for reference for the purpose of later resetting to that same setting.

For example: In the event that a board being planed becomes jammed due to taper, twist, etc.:

1. Press the HOLD button. The dimension is "frozen" in the display.
2. Lower the table to remove the jammed board. After the jammed board is removed...
3. Make a mental note of the "frozen" dimension (from Step 1).
4. Press HOLD again to return to normal measurements
5. Adjust the table back to its original (frozen display) position.

## TOL

Tolerance is an intrinsic feature of the DRO and is not used in planer operation.

## Parts List

Index No.	Part No.	Description	Size	Qty
1.....	JWPDRO-01 .....	Upper Plate .....		1
2.....	TS-2279301 .....	Set Screw.....	M10x30.....	1
3.....	TS-1540071 .....	Hex Nut.....	M10.....	1
4.....	JWPDRO-04.....	Lower Plate .....		1
5.....	TS-1550041 .....	Flat Washer (For 15" Planer) .....	M6.....	1
.....	TS-1550061 .....	Flat Washer (For 20" Planer) .....	M8.....	1
6.....	TS-1503071 .....	Socket Head Cap Screw (For 15" Planer) .....	M6x30.....	1
.....	TS-1504061 .....	Socket Head Cap Screw (For 20" Planer) .....	M8x30.....	1
7.....	TS-1531012.....	Screw.....	M3x6.....	2
8.....	JWPDRO-08.....	Digital Readout Body and Scale.....		1
9.....	15S-601 .....	Battery Cover .....		1
10.....	TS-1550021 .....	Flat Washer.....	M4.....	1
11.....	TS-2171012.....	Screw.....	M4x6.....	1
12.....	15S-600.....	Battery.....	1.5 Volt.....	2

## Ordering Replacement Parts

To order parts or reach our service department, call 1-800-274-6848 between 8:00 a.m. and 5:00 p.m. (CST), Monday through Friday. Having the Model Number and Serial Number of your machine available when you call will allow us to serve you quickly and accurately.

*The specifications in this manual were current at time of publication, but because of our policy of continuous improvement, JET reserves the right to change specifications at any time and without prior notice, without incurring obligations.*

## Parts

### Exploded View

